



**US Army Corps
of Engineers®**

Life Jacket Loaner Program Guidelines

15 April 2011

Table of Contents

I. Purpose	1
II. Applicability	
III. Background	
IV. Summary of Guidance	2
V. Specific Guidance	
VI. Procurement of Loaner Program Materials	4
VII. Communications Plan and Public Education Initiatives	
VIII. Examples of Two Types of Loaner Programs	5
Appendices:	
A - Potential Partnership Opportunities	
B - Life Jacket Loaner Station Sample Inspection/Restocking Logs	
C - Life Jacket Loaner Sign-Out and Liability Form (English, Spanish)	
D - Sample Letter to Borrowers for Unreturned Life Jackets	
E - Life Jacket Loaner Program Sample Communications Plan	
F - Sample Life Jacket Loaner Stations Design Plans and Photos	
G – Life Jacket Loaner Program Policy dated 23 July 2010	

I. Purpose. This document provides guidance to establish minimally acceptable standards for design, construction, maintenance, public information and program implementation for US Army Corps of Engineers (USACE) managed life jacket loaner stations. This document does not mandate loaner station use, but provides guidelines to be met if loaner stations are installed or maintained by the USACE.

II. Applicability. These guidelines apply to all USACE projects implementing or managing any type of life jacket loaner program.

III. Background.

The life jacket loaner program provides the public with free use of life jackets on a first-come, first-served basis, while recreating at USACE lakes and waterways. Research shows that 90 percent of drownings at USACE projects could have been prevented if a life jacket had been worn by the victim. The goals for this program are to increase life jacket wear during water-based activities on USACE lakes and waterways as well as educate the visiting public on the importance of proper use and fit.

Life jacket loaner stations have been successfully used since the mid-1980s by various USACE lake operations project managers as a tool in reducing public recreation-related fatalities on their waters. Most of these stations offer various sizes of life jackets from infant to adult in limited quantities. Demand for use of the life jackets has generally exceeded the available supply. Many of the loaner stations in existence at USACE facilities have cooperatively been installed and maintained by local partners, such as Safe Kids Coalition, Boy or Girl Scout organizations, or local water safety councils. The standards for each station have been at the discretion and control of the local lake manager. This resulted in a variety of structure design, maintenance, and oversight in monitoring the structures or the life jackets being made available to the public.

In April 2007, MG Don Riley, then the Director of Civil Works for USACE, directed the National Operations Center for Water Safety (NOC) to conduct a study on the benefits and impacts of establishing a policy requiring visitors to wear life jackets while recreating on Corps-managed waters. After careful review of findings, the study team recommended development of a national life jacket loaner program among other options. General Riley endorsed that recommendation. See Life Jacket Mandate Study Interim Report, dated 2 May 2008 at this link. <http://corpslakes.usace.army.mil/employees/watersafety/pdfs/LJMSInterimReport.pdf>

In July 2010, Michael Ensich, Chief, Operations Directorate of Civil Works, established a Life Jacket Loaner Policy. This policy was issued to clarify the use of appropriated funds for purchasing supplies and materials to establish and maintain life jacket loaner programs on USACE projects. See Appendix G Life Jacket Loaner Policy Memorandum, dated 23 July 2010. This is also available online under policy memos at this link. <http://corpslakes.usace.army.mil/employees/policy.cfm?Id=watersafety&Code=All>

Life Jacket Loaner Programs have been heavily encouraged by such national partners as Safe Kids Worldwide, BoatUS, US Coast Guard, Children's Hospital Network, National Safe Boating Council, National Drowning Prevention Coalition, National Association of State Boating Law Administrators and National Water Safety Congress. See Appendix A for potential partners.

IV. Summary of Guidance.

- A. All USACE recreation projects are strongly encouraged to implement a life jacket loaner program.
- B. Life jacket loaner programs may be managed at staffed locations (such as gatehouses or visitor centers) or by use of unstaffed loaner boards or kiosk-type stations.
- C. Possible locations for loaner stations include gatehouses, visitor centers, designated swim beaches, marina offices, fuel docks, boat ramps, or similar high visibility facilities.
- D. Loaner station design and program execution, to include routine maintenance and inspections, will be at the discretion of the Operations Project Manager or Natural Resource Managers using this guidance.
- E. Signage, printed material, or trained personnel, must be available to provide the public information on how to properly size and fit a life jacket.
- F. All loaner program printed materials should be printed in language(s) appropriate to project visitation. Display or availability of information offering visual guidance should be used whenever possible.

V. Specific Guidance.

A. Structure Design & Inspections

- 1. Single Purpose – A loaner board or kiosk should be used only for promotion of life jacket wear and associated printed materials. Do not use the kiosk as a general information bulletin board as well.
- 2. Readily accessible – The loaner board or kiosk should be highly visible and readily accessible. If possible, it should be accessible by wheelchair.
- 3. Safe structure – The kiosk or loaner board should be designed and made from materials appropriate to local weather conditions. See Appendix F for design ideas. Weather resistant materials are preferable to reduce maintenance and damage to the board. Any type of hook or post used to display life jackets should be blunt and placed at an appropriate height above child’s eye level. Do not use sharp or extended attachments, such as nails, to hang the jackets. The structure’s design should also meet district and/or project standards for bulletin boards or other kiosk structures.
- 4. Structure Inspections - The life jacket loaner board or kiosk must be inspected on a regular basis. Project staff will determine the frequency of inspections. The inspection should identify damage or wear from use and follow-up maintenance requests accordingly. Any damage or wear that could cause injury, or poses a threat to a visitor must be fixed immediately or removed from public availability.

B. Life Jackets Inspections

- 1. Schedule – It is important that life jackets be inspected on a routine basis. Project and/or district staff will determine frequency of inspections; however a weekly inspection is recommended for unmanned loaner stations. Staffed loaner station locations should

include standards for inspection of jackets as they are returned from visitors, or on a rotational basis.

2. Reports – Inspection/Restocking log reports should be appropriately filed and maintained at the site’s project management office for three years for liability purposes. See Appendix B for a sample form.

3. Personnel – Life jacket inspections should be conducted by park rangers, other staff members, contractors, volunteers, or others assigned by the USACE. Project staff will determine and put into writing required inspection steps, but include specific standards for assessing unacceptable wear or damage. It is recommended that all inspectors be properly trained on inspection criteria and other elements of loaner program management.

4. Life jacket inspection checklist - Any jackets not meeting inspection criteria set by project staff must be removed from loaner station/program and destroyed.

(a) Check for holes, tears, rips or severe pulling around all seams (especially around straps)

(b) Check that buckles and zippers work correctly

(c) Check for signs of mildew, mold or deteriorating discoloration, such as excessive fading from sunlight

5. Life jacket inventory- Every effort should be made to have an inventory of extra life jackets on hand to replace damaged or lost jackets. A sample letter to borrowers who do not return loaner jackets is in Appendix D.

6. Off-season - It is suggested that during winter (or months of traditionally low visitation) that jackets be stored inside to reduce amount of damage from severe weather. Most projects pull all life jackets in from swim beaches during the winter months or if a recreation area has been closed.

C. Printed Materials/Signage

1. Signs or printed materials will be posted on or adjacent to life jacket loaner stations to address fit, size, and condition as follows. All materials will be printed in languages appropriate for visitor communication.

a. Fit – With text or graphics, show a properly fitting and buckled life jacket.

b. Size – Show visitors how to locate sizing information on the life jacket label or restate the weights associated with each size.

c. Condition – Provide visual or written guidance on the importance of checking for damage on life jackets before using them.

2. Printed information on fit and sizing will be provided even if gate attendants (or other personnel) are fitting jackets for visitors. Visitors must be made aware of their personal responsibility in choosing a properly fitting life jacket in good condition.

3. Signs and other materials should be simple and easily understood – consider using graphics if at all possible.

4. Printed materials and signs should provide directions to visitors as to how the loaner program works. For example: Where do they return life jackets? Are there conditions for the program (do visitors have to sign a form, work through a gate attendant, or just borrow and return the life jackets?)

5. Go to the National Operations Center for Water Safety pages on the NRM Gateway, for appropriate artwork, sign format and content.

VI. Procurement of Loaner Program Materials. The CECW-CO Life Jacket Loaner Policy, dated 23 July 2010, (Appendix G) clarifies our authority to use appropriated funds to purchase life jacket loaner station supplies and materials. However, whenever practical, partnerships should be used to minimize operating costs. Projects with existing loaner programs have successfully partnered with non-profits, local merchants, civic organizations, and water safety councils to obtain life jackets (Appendix A). Sample design plans and associated costs are in Appendix F.

VII. Communications Plan and Public Education Initiatives.

Projects are encouraged to develop a media campaign and communications strategy to increase awareness about the life jacket loaner program. The communications plan should include a draft news release with photos and interpretive posters explaining the program. Each project is encouraged to tailor draft news releases and posters for their site. The Plan should include talking points for rangers and other personnel. All materials will be developed in languages appropriate for project visitation. See Appendix E for a sample Communications Plan and sample press releases and talking points. Project promotions may include:

A. Recreation Area Promotion

1. Posters explaining the life jacket loaner program displayed on bulletin boards and/or gate houses.
2. Information posted at boat ramps that will educate boaters about the loaner program.
3. Where applicable, gate attendants/hosts will have information/training about this program so they can sign out life jackets to borrowers.

B. Visitor Center Promotion

1. Include information about the life jacket loaner program as part of a water safety education display.
2. Where applicable, inform and train visitor center volunteers and staff about this program so they can familiarize visitors with the program.

C. Out-granted Areas, Partnering Organizations, and Agencies Promotion

1. Projects are encouraged to partner with operators of out-granted areas to develop life jacket loaner sites at their areas.

VIII. Examples of Two Types of Loaner Programs

- A. Staffed Loaner Stations (e.g. gatehouses, visitor centers, project offices etc.):
1. Location should display prominent signage promoting the loaner program. Life jackets should be readily available and visible.
 2. Loaner stations should be stocked with US Coast Guard approved life jackets in various sizes, in limited quantities.
 3. Attendants may ask park visitors if they would like to borrow a free loaner life jacket for the day.
 4. Borrower may be required to complete a form (Appendix B) providing their name, contact information, size of jacket, number on jacket, etc. Borrower will be reminded to return life jacket upon departure from park. The use of this form is not mandatory, but may be used at the discretion of the Operations Project Manager. In the event that a life jacket is not returned, this gives USACE the opportunity to phone or write the borrower requesting the life jacket be returned. See sample in Appendix D. Actual level of program enforcement will be determined by the Operations Project Manager.
 5. Life jackets must be inspected on a routine basis for wear and unsafe life jackets removed. Inspection reports should be kept on file for 3 years for liability purposes.
 6. Interpretive posters, signs, or other types of notices may be posted at launch ramps, visitor centers, restrooms, swim beaches, etc., to increase visitors awareness about the program and encourage boating and water safety. Bilingual signage may be provided at manager's discretion.
- B. Unstaffed Loaner Stations:
1. Loaner station at swim beaches, boat ramps, marinas, or similar facilities should have signs, posters, or other types of notices explaining the loaner program.
 2. US Coast Guard approved life jackets should be available in various sizes.
 3. Loaner station signs should instruct visitors who borrow life jackets on an honor system to return the jacket to the station before leaving the park.
 4. Life jackets must be inspected on a routine basis for wear and unsafe life jackets removed. Inspection reports should be kept on file for 3 years for liability purposes.
 5. Posters, signs, or other types of notices may be posted at launch ramps, visitor centers, restrooms, swim beaches, etc., to increase visitors' awareness about the program and encourage boating and water safety. Bilingual signage may be provided at manager's discretion.

Appendix A
Potential Partnership Opportunities

PFD Donations/Discounts/Grants:

Local water safety councils
Cooperating Associations
Walmart
Target
West Marine/ Port Supply
Stearns
Mustang
Revere
Walsh Marine
Dicks Sporting Goods
Sports Authority
Local sporting goods/outdoor stores
Boat U.S. Foundation
National Safe Boating Council
Safe Kids Coalition
National Marine Manufacturers Assoc.
Yamaha
Kawasaki
Mercury Motors
Ranger Boats
Zodiac
Rotary
Lions Club
Ruritan
Civitan
Kiwanis
Shriners
YMCA
American Red Cross
American Legion
Religious organizations

Loaner Tree Material Donations/Discounts:

Home Depot
Lowe's Home Improvement Warehouse
Ace Hardware
True Value Hardware
Local hardware stores
Walmart
Target

Other Partners

US Coast Guard
US Coast Guard Auxiliary
US Power Squadrons
National Water Safety Congress
Kids Don't Float campaign – Alaska

Appendix B
Life Jacket Loaner Station Sample Inspection/Restocking Logs

Instructions:

- Check stations on mornings prior to whenever the loaner station location gets the most use (i.e. weekends, holidays).
- A mixture of sizes of life jackets is highly recommended, but the quantity may vary depending on the stations usage needs. For a location with high visitation, it is suggested to provide approximately 12 Child, 18 Youth, and 6 Adult life jackets.
- Buckle up all clips to ensure they hold and check for the following damage.
 - Rips or tears in the fabric
 - Buckles won't clasp (check for rocks/sand that could be removed)
 - Very faded fabric (fabric will feel very thin and look almost white at seams)
- If any damage is found, remove and replace the jacket, even if you're not sure.
- Complete form and put in Loaner Station Manager's inbox.

Life Jacket Loaner Station Inspection/Restocking Log:

Inspector Name: _____ Date: _____

Location	Number Adult Replaced	Number Youth Replaced	Number Child Replaced	Jackets Missing	Jackets Damaged

Completed Form Example – If there were 2 adult, 2 youth missing and 1 adult and 1 child damaged at a certain location, that line of the form would look like this:

Location	Number Adult Replaced	Number Youth Replaced	Number Child Replaced	Jackets Missing	Jackets Damaged
Holly Point North	3	2	1	2A, 2Y	1A, 1C

Appendix C
Sample Life Jacket Loaner Sign-Out and Liability Form

Life Jacket Loaner Program Form

Date Issued _____ **Loaned by** _____

Name of Guardian or Responsible Adult: _____

Mailing Address: _____

Phone numbers- Work: _____ Home : _____

Cell: _____

Driver License Number and State: _____

Vehicle Tag Number and State: _____

Due Date and Time: _____ Date and Time Returned: _____

Activity to be used: (Circle one) Swimming Boating Fishing

Number of Life Jackets loaned: _____ Size of Life Jackets: _____

By signing this document, you, the borrower, certify that you have inspected all life jackets being borrowed for appropriate fit and function. You, the borrower, agree to indemnify and hold harmless the loaner and the U.S. Army Corps of Engineers against all claims, losses, damages, and any and all liabilities associated with this agreement and the loan of all life jackets as provided to you. The U.S. Army Corps of Engineers offers this program as a free public service using US Coast Guard approved equipment. As the U.S. Army Corps of Engineers has no control over actual usage, they assume no liability for the use or misuse of the life jackets. Personal information recorded on this form will only be used for purpose of ensuring the proper return of the life jackets. Your personal information will not be shared with other parties.

Signature of Guardian or Responsible Adult:

Appendix C
Formulario de Préstamo de Chalecos Salvavidas

Fecha _____ Prestado Por _____

Nombre del adulto responsable: _____

Dirección: _____

Teléfono del trabajo: _____ Casa: _____

Celular: _____

Número y estado de la licencia de conductor: _____

Número y estado de la placa del vehículo: _____

Fecha y hora de vencimiento: _____ Fecha y hora de entrega: _____

Actividad para la cual se utilizará: (circule uno) Paseo en bote Nadar Pesquera

Número de chalecos salvavidas prestados: _____ Tamaño de los chalecos salvavidas: _____

Al firmar éste documento, usted, el prestatario, certifica que usted ha examinado todos los chalecos salvavidas que serán pedido prestados en cuanto a tamaño y función. Usted, el prestatario, acuerda indemnizar y liberar de toda culpa el prestador y el U.S. Army Corps of Engineers de cualquiera responsabilidad, pérdida y daños asociados con éste acuerdo y el préstamo de los chalecos salvavidas. El prestador y el U.S. Army Corps of Engineers ofrecen el uso de este programa gratuito al público, utilizando equipo aprobado por el U.S. Coast Guard. Como ni el prestador ni el U.S. Army Corps of Engineers tienen control sobre el uso actual de los chalecos salvavidas, ninguno de los dos se hacen responsables por el uso indebido de los mismos. La información personal registrada en esta forma será utilizada solamente para los propósitos constantes con la razón proporcionada. Su información personal no ser compartida con otros partidos.

Firma del adulto responsable:

Appendix D
Sample Letter to Borrowers for Unreturned Life Jackets

The following is a sample letter to send to remind borrowers to return life jackets. It is at the discretion of the Operations Project Manager to determine the level of enforcement to be used for this program.

Dear (borrower):

Our records show that you borrowed (insert number) life jacket(s) on (date) and forgot to return (it/them). Please return the jacket to (project site) as soon as possible. The life jacket loaner program depends on life jackets being returned for others to use.

Thank you for your cooperation with this matter. Please contact (name and phone number) if you have any questions regarding this matter.

Sincerely,
(name of person in charge of program)
(Title)
(Project name)
(XXX District)
U.S. Army Corps of Engineers

Appendix E

Life Jacket Loaner Program Sample Communication Plan

- 1. Purpose:** This document provides a communication strategy template for project offices, in cooperation with local PAO, to use in launching a new life jacket loaner program campaign or to increase awareness enhance an existing program.

- 2. Responsibilities:**
 - a. All personnel should reference this plan when fielding questions/concerns from members of the public, partners, and/or stakeholders of lake projects.
 - b. Field staff should work with district Public Affairs Office (PAO) to distribute news releases/and or media advisories to increase awareness.
 - c. Field staff should conduct direct outreach with visitors and partners/stakeholders to explain the program.

- 3. Background:** The life jacket loaner program provides the public with free use of life jackets while visiting USACE recreation areas. Research shows that 90 percent of water-related fatalities at USACE projects could have been prevented if a life jacket had been worn by the victim. The goals for this program are to increase life jacket wear during water-based activities on USACE recreation lakes and waterways as well as educate the visiting public on the importance of proper use and fit.

Life jacket loaner stations have been successfully used since the mid-1980s by various USACE lake operations project managers as a tool in reducing public recreation-related fatalities on their waters. Most of these stations offer various sizes of life jackets from infant to adult on a first-come, first-served basis. Demand for use of the life jackets has generally exceeded the available supply. Many of the loaner stations in existence at USACE facilities have cooperatively been installed and maintained by local partners, such as Safe Kids Coalition, Boy or Girl Scout organizations, or local water safety councils. The standards for each station have been at the discretion and control of the local lake manager. This resulted in a variety of structure design, maintenance, and oversight in monitoring the structures or the life jackets being made available to the public.

In April 2007, MG Don Riley, then the Director of Civil Works for USACE, directed the National Operations Center for Water Safety (NOC) to conduct a study on the benefits and impacts of establishing a policy requiring visitors to wear life jackets while recreating on Corps-managed waters. After careful review of findings, the study team recommended development of a national life jacket loaner program among other options. General Riley endorsed that recommendation. See Life Jacket Mandate Study Interim Report, dated 2 May 2008 at this link.

<http://corpslakes.usace.army.mil/employees/watersafety/pdfs/LJMSInterimReport.pdf>

In July 2010, Michael Enschede, Chief, Operations Directorate of Civil Works, established a Life Jacket Loaner Policy. This policy was issued to clarify the use of appropriated funds for purchasing supplies and materials to establish and maintain life jacket loaner programs on USACE projects. See Life Jacket Loaner Policy Memorandum, dated 23 July 2010, under

policy memos at this link.

<http://corpslakes.usace.army.mil/employees/policy.cfm?Id=watersafety&Code=All>

Life Jacket Loaner Programs have been heavily encouraged by such national partners as Safe Kids Worldwide, US Coast Guard, Children's Hospital Network, National Safe Boating Council, National Drowning Prevention Coalition, National Association of State Boating Law Administrators and National Water Safety Congress.

4. Potential Audiences

a. Internal

- (1) Park staff
- (2) Sister/neighboring projects
- (3) Operations leadership
- (4) Command group

b. External

- (1) Nearby vendors/concessionaires
- (2) Local residents who regularly visit the recreation areas
- (3) Local law enforcement agencies that patrol/respond to the recreation areas
- (4) Marina tenants
- (5) Local media
- (6) Local civic groups/clubs (Rotary, Lions, American Legion, Fishing Clubs, etc.) that have a vested interest in the facility
- (7) Community leaders (city/town council reps, county reps, congressional district reps, teachers)

5. Goal, Strategy, Tactics:

Goal: Ensure awareness of life jacket loaner program and increase awareness of Corps' commitment to visitor/water safety.

Strategies: Communicate program intent and policy proactively through internal briefings, media releases, social media outreach and direct visitor interaction.

Suggested Tactics:

- a. News release announcing program
- b. Water safety event at park to introduce program
- c. Facebook, Twitter announcements about program
- d. Distribute fact sheet to local businesses, partner agencies
- e. Pitch ranger/manager appearances on local radio/TV stations to discuss program
- f. Direct outreach to partners/stakeholders

6. Key Messages and Talking Points

a. Life jackets save lives.

- Since 1998, 90 percent of drowning victims on Corps waters were not wearing life jackets.

- When accidents happen, life jackets buy time for successful rescues.
- b. Accidents happen. They don't have to be fatal.
- Many people who drown never expected to end up in the water. Even experienced swimmers can quickly get into trouble.
 - Safe boating isn't just the responsibility of the person behind the wheel; it applies to everyone on board.
 - Most boaters do not plan on falling overboard, and when they do, it is too late. Putting on a life jacket when you need it is like trying to put on a seat belt just before a crash.
 - Adults can drown in less than a minute; children in as few as twenty seconds.
 - More than 150 people die at Corps parks each year on average. Many of these deaths might have been prevented by life jackets.
- c. The safety of our visitors is our top concern.
- Life jackets are essential to safe water recreation, and we want everyone who visits our park to be able to do so safely.
 - Providing loaner life jackets to our visitors ensures all visitors to our park have the chance to enjoy it safely.
 - Our park rangers are always happy to assist visitors with proper life jacket wear and to share advice for safe boating and swimming.
- d. Following some simple rules can help you stay alive.
- Always wear a life jacket.
(*Siempre use un chaleco salvavidas.*)
 - Children should wear life jackets when playing in or near the water.
(*Niños deben usar chalecos salvavidas al jugar adentro o cerca del agua.*)
 - Everyone should wear life jackets from the time they arrive at the boat ramps until they tow boat out of the water.
(*Cada uno debe usar chalecos salvavidas a partir del tiempo momento que llegan a las rampas de botes hasta que remolquen el bote fuera del agua.*)
 - If you don't have a life jacket, talk to a ranger or park attendant about our loaner program.
(*Si usted no tiene un chaleco salvavidas, hable con un guarda parques o un asistente del parque sobre nuestro programa al prestamista.*)
 - Always swim with a buddy.
(*Nada siempre con un amigo.*)
 - Learn how to swim well.
(*Aprende a nadar bien.*)
 - Never dive into unknown waters.
(*Nunca se zambulla en las aguas desconocidas.*)
 - Parents, always watch your children!
(*¡Padres, vigilen siempre a sus niños!*)
 - Always swim in designated areas.
(*Siempre nade en áreas designadas.*)

- Take a Boating Safety Course.
(Tome un curso sobre la seguridad del paseo en bote.)
- Always be weather wise, watch for summer storms.
(Conozca el estado del tiempo, vigile por las tormentas del verano.)



NEWS RELEASE

U.S. ARMY CORPS OF ENGINEERS

BUILDING STRONG®

For Immediate Release:
(insert date)

Contact: (insert POC's name)
(insert phone number)
(insert email address)

Life Jacket Loaner Program at (insert project name)

(Insert Project Name, State Abbreviation) – (insert project name), managed by the U.S. Army Corps of Engineers, (insert district name), will offer a limited number of life jackets for loan to park visitors beginning (insert Month Date, Year).

“Quote from park manager describing why the park has chosen to implement the program and how it's expected to improve safety at the park,” said park manager – insert name)

Many U.S. Army Corps of Engineers lake and river projects have managed life jacket loaner programs since the 1980s. In March 2011, U.S. Army Corps of Engineers headquarters established national guidelines for loaner programs to bring consistency within the agency and to reinforce their commitment to water safety.

“Statistically, we know that 90 percent of our drowning victims were not wearing life jackets. In many of these incidents, we know that life jackets, if properly worn, would have increased their chances of survival,” said Lynda Nutt, manager of the U.S. Army Corps of Engineers' National Operations Center for Water Safety.

(District describe particulars of local program)

The life jacket loaner program is a supplement program for those visitors who forgot their life jacket. Visitors should not rely on this program as a sole source for their life jackets. If a life jacket is borrowed from the loaner program it should be returned the same day it is borrowed.

Visitors with questions about the program are encouraged to contact the (insert project name) project office at (insert phone number).

The U.S. Army Corps of Engineers is America's largest provider of outdoor recreation opportunities on federal public lands, serving more than 350 million visitors per year at over 400 lake and river projects in 43 states.

-###-

U.S. ARMY CORPS OF ENGINEERS – ENTER DISTRICT DIVISION NAME HERE

ENTER ADDRESS HERE
ENTER WEB ADDRESS HERE



LIFE JACKET LOANER PROGRAM

U.S. ARMY CORPS OF ENGINEERS

BUILDING STRONG®

Background

In March 2011, U.S. Army Corps of Engineers headquarters issued guidelines for implementing life jacket loaner programs throughout the agency nationwide. Many U.S. Army Corps of Engineers lake and river projects have managed loaner programs independently since the 1980s. The new guidelines will ensure consistent loaner programs across the nation as an agency and reinforce the agency's commitment to ensuring the safety of more than 350 million visitors per year to over 400 lake and river projects in 43 states.



Life Jackets Save Lives

More than 150 people die at U.S. Army Corps of Engineers' lake and river projects each year on average, most of them by drowning. Since 1998, 90 percent of drowning victims on U.S. Army Corps of Engineers waters were not wearing life jackets. U.S. Coast Guard boating regulations require vessels to carry a life jacket for each passenger, but they only work if you wear them. Many drowning victims never intended to end up in the water. When accidents happen, life jackets buy time for successful rescues. The life jacket loaner program helps ensure all visitors to U.S. Army Corps of Engineers' lake and river projects have a safe visit.

The Life Jacket Loaner Program at (insert your project name)

The loaner program is a supplement program for those visitors who forgot their life jacket. Visitors should not rely on this program as a sole source for their life jackets. If a life jacket is borrowed from the loaner program it should be returned the same day it is borrowed.

Describe the particulars of your life jacket loaner program.

For More Information

More details on park policy and contact info.

U.S. ARMY CORPS OF ENGINEERS – ENTER DISTRICT DIVISION NAME HERE

ENTER ADDRESS HERE

ENTER WEB ADDRESS HERE

**Appendix F
Sample Life Jacket Loaner Station
Design Plans and Photos**

Tree of Life – Design #1 – Treated Wood Construction

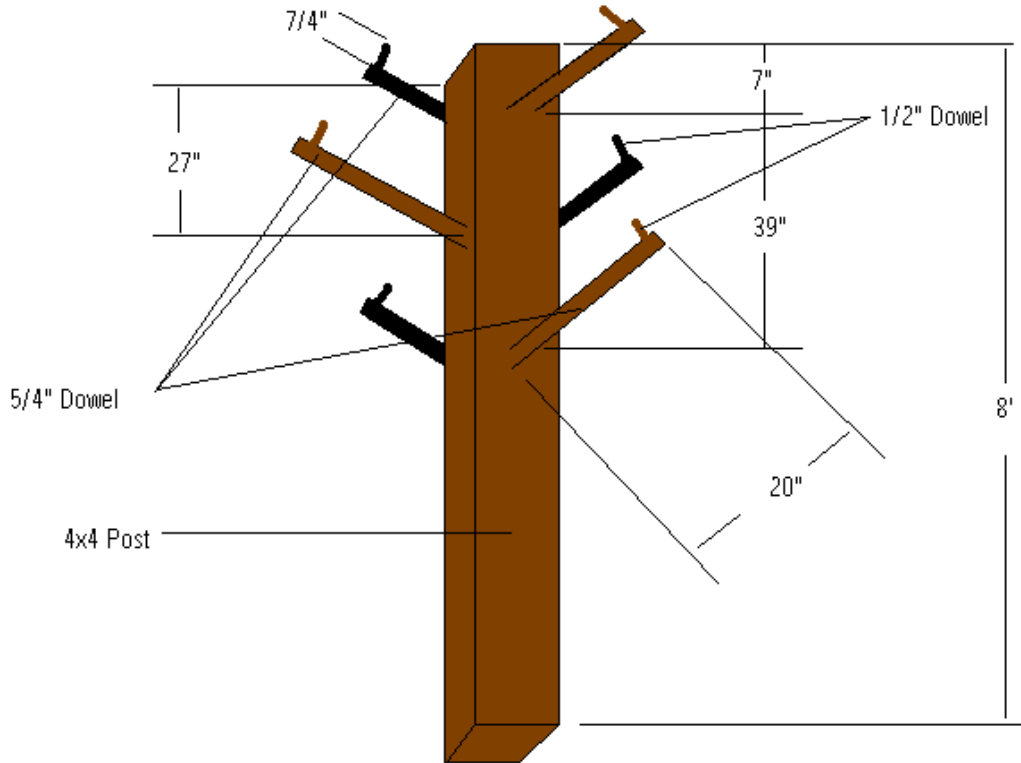

Post-	\$ 5.97
5/4"x6' Dowel-	\$ 6.40
1/2 x4' Dowel-	\$ 1.38
Water proof Glue-	\$12.48

**Contact: Jordan Lake, SAW
Cost Estimate: \$20 materials**

Pros

- Inexpensive
- Simple to construct
- Easy to maintain – no metal to rust
- Minimal size, small profile

Cons

- Peg height may present safety hazard, if near eye levels
- Lack of space for signage to address fit, size, condition of jackets
- Fixed structure may be impacted by high water conditions
- Jackets may blow off in high winds
- No roof – jackets exposed to weather & sun conditions



Tree of Life – Design #2 – PVC Construction

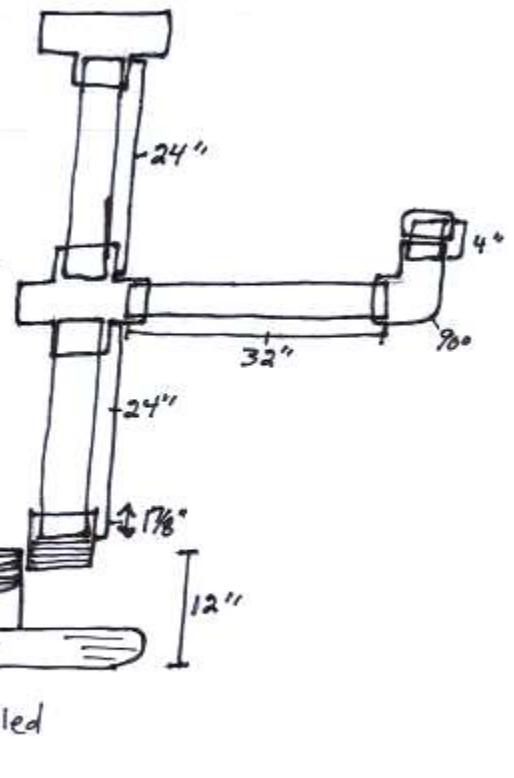

Contact: Lake Shelbyville, MVS

Cost Estimate: \$260 materials

Pros

- Inexpensive
- Simple to construct
- Semi-mobile
- Easy to maintain – no metal to rust
- High visibility
- Sturdy Design

Cons

- Minimal space for signage to address fit, size, condition of jackets
- No roof jackets exposed to weather and sun conditions

Materials needed to construct one Tree of Life

- 22 feet of schedule 80 three inch pipe
- One 4 way cross 3" schedule 80
- One 3 way T 3" schedule 80
- Four 90 degree elbow 3" schedule 80
- Four end caps 3" schedule 80
- One 3" x 12" black pipe nipple
- One 3" adapter
- 1 pint of clear pipe glue
- One old car tire
- One or Two bags of secrete depending on size of tire

Kiosk Design - #1 – Steel Construction



Contact: Waurika Lake, SWT
Cost Estimate: Total \$750-\$1200 (Sign only \$275)

Pros

- Substantial Structure for displaying appropriate messages and jackets
- Has small roof to protect jackets and signs somewhat
- Single use structure
- High visibility
- Easily maintained steel structure

Cons

- More expensive than tree stations
- More complex construction
- Graphics on sign need improvements (e.g. all caps text not good)

Kiosk Design - #2 – Treated Wood Construction

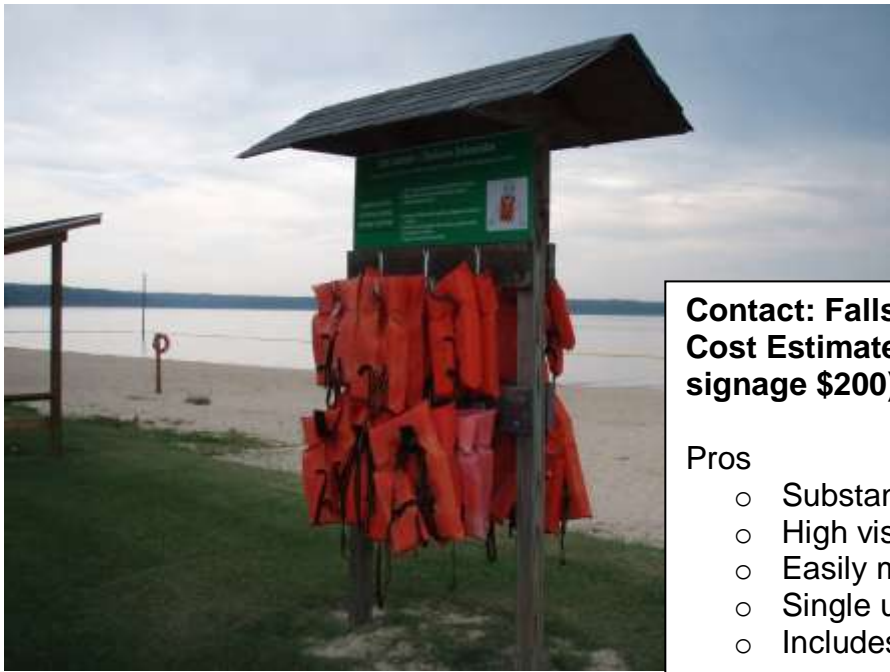

Contact: Falls Lake, SAW
Cost Estimate: Total \$500 (materials \$300, signage \$200)

Pros

- Substantial structure for messages
- High visibility
- Easily maintained
- Single use structure
- Includes signage addressing proper use and bilingual

Cons

- More expensive than 'tree' stations
- More complex construction
- Message says return but not before leaving.
- Message doesn't thoroughly address proper sizing of jackets.

Life Jackets - Chalecos Salvavidas

Please borrow and return - Tome prestado uno y devuélvalo después de usarlo

Child Size- 30-50 lbs

Youth Size- 50-90 lbs

Adult Size- Over 90 lbs

1. Pick a life jacket that fits and place jacket over head
2. Wrap buckle around waist and fasten to secure
3. Tighten strap if needed

1. Escoja un chaleco que le quede y coloca chaqueta sobre tu cabeza.
2. Pase la correa alrededor de la cintura y ajuste la hebilla para asegurar el chaleco
3. Ajuste la correa si es necesario



Enclosed Design #1



- **6'x3' plastic (PVC) building – donated from local hardware store**
- **Includes room on doors and inside building to hang proper signage**

Contact: DeGray Lake, MVK

Cost: Donated building + Cost of signage

Pros

- Substantial structure
- Easily maintained
- Includes proper signage
- Good protection from sun and weather damage

Cons

- Possibly expensive option (unless shed is donated)
- Space available but inadequate signage to address proper size and fit.
- Needs a high visibility area or signage to direct visitors to structure

Enclosed Design #2



Contact: Grapevine Lake, SWF
Cost Estimate: Total \$850 (materials \$750, signage \$100)

Pros

- Substantial structure
- High visibility
- Signage easily updated or exchanged
- Dual use: Water Safety + Interp
- Includes proper signage
- Rotates to account for wind change through the year
- Can be easily converted to full interp during non-rec season

Cons

- More expensive than 'panel' stations
- More complex construction
- Takes more space than 'panel' stations
- Life jackets not secured during night hours (no doors on structure)

LIFE JACKET LOANER STATION

RULES & REGULATIONS:

- 1) Life jackets are available on a first-come-first-serve basis.
- 2) If you need a life jacket, and there are none available, notify the park attendant and one will be supplied to you.
- 3) Parents/Guardians are responsible for making sure their children are in the right sized life jacket. If the size is incorrect, the life jacket will not work effectively.
- 4) Borrower assumes all responsibility and liability of life jacket use/non-use.
- 5) Borrower will not hold liable any party involved in the distribution of lifejackets.
- 6) Borrower must inspect life jacket prior to use to make sure life jacket is in good working condition.
- 7) Return life jackets to this station before leaving the park!

THANK YOU FOR YOUR COOPERATION!

¡Para la información en español, lee por favor el otro lado!!



Provided by
 US Army Corps of Engineers
 Fort Worth District
 Trinity Regional Project

This material has been funded in part by a grant from the National Water Safety Congress in cooperation with the U.S. Coast Guard Office of Boating Safety administering the Sport Fish Restoration & Boating (Stake-Breaker) Trust Fund

LOS CHALECOS SALVAVIDAS SE PUEDE USAR GRATIS

NORMAS Y REGLAMENTOS:

- 1) Los chalecos salvavidas están disponibles por orden de llegada.
- 2) Si necesita un chaleco salvavidas y no hay ninguno disponible, notifíquese al encargado del parque, quien le dará uno.
- 3) Los padres/ tutores son responsables de asegurarse de que sus hijos utilizan un chaleco salvavidas de su talla. El chaleco salvavidas no funcionará eficazmente si la talla no es la correcta.
- 4) El usuario del chaleco salvavidas asume toda responsabilidad respecto al uso o no del chaleco salvavidas.
- 5) El usuario no responsabilizará a ninguna de las partes relacionadas con la distribución de los chalecos salvavidas.
- 6) El usuario debe inspeccionar el chaleco salvavidas antes de usarlo para asegurarse de que funciona correctamente.
- 7) Favor de devolver el chaleco salvavidas a este mismo lugar antes de abandonar el parque.

¡MUCHAS GRACIAS POR SU COOPERACIÓN!

For information in English, please see other side!



Proporcionado por
 US Army Corps of Engineers
 Fort Worth District
 Trinity Regional Project

This material has been funded in part by a grant from the National Water Safety Congress in cooperation with the U.S. Coast Guard Office of Boating Safety administering the Sport Fish Restoration & Boating (Stake-Breaker) Trust Fund

Enclosed Design #3

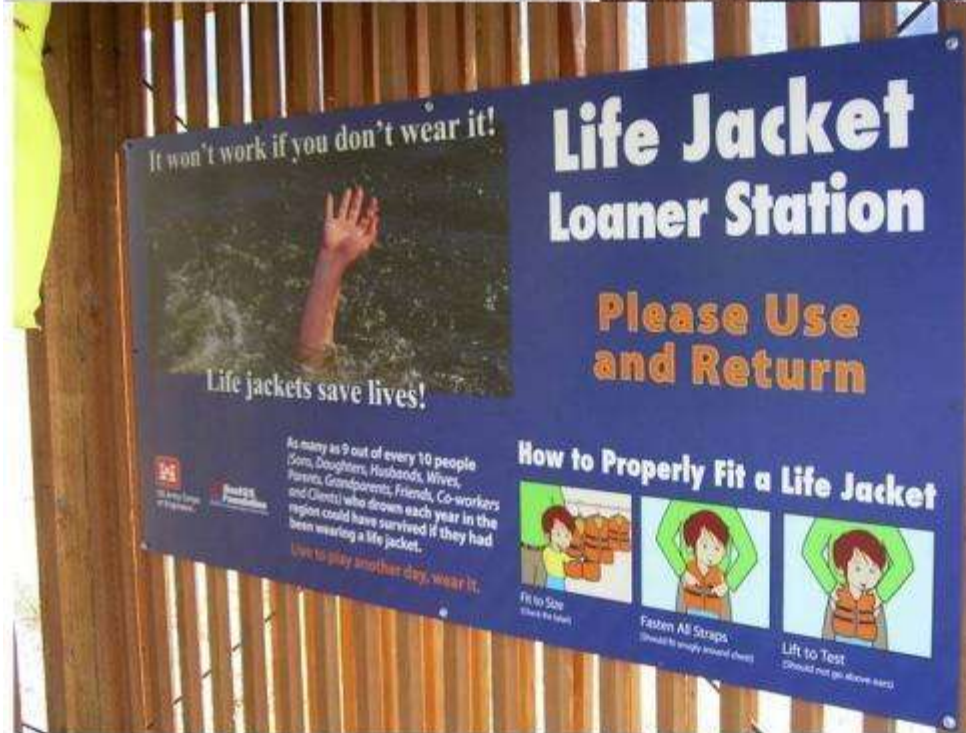

Bonneville Dam,
Hamilton Island
Boat Ramp
September 4, 2010

Total Cost: \$14,000 Materials, Labor and Signage

Pros: Substantial Structure

High Visibility

Easily Maintained

Signage

Professional

Cons: Expensive

Message doesn't request returning the same day

English only

Jackets not secured overnight

Dock Box Design



Contact: Wallisville Lake, SWK
Cost: Donated materials and labor. No cost estimate available.

Pros

- High visibility
- Easily maintained
- Includes proper signage
- Good protection from sun and weather damage

Cons

- More expensive option with both the covered sign and dock box
- The dock box came unvented (could have been a suffocation hazard) so a vent with a screen (to keep out wasps!) was installed in the back.
- Ventilation needs to be adequate to prevent mold and mildew conditions that deteriorate jackets.

Graphics/Resources

US Army Corps of Engineers

Wear It, Wear It Right Life Jackets Save Lives!

- ## 1 CHECK THE LABEL

The label will tell you:

 - Whether the life jacket is Coast Guard approved.
 - The size of the jacket.
 - How the jacket can be used.

Sizes run from infant to extra extra large. Adult life jackets will not work for children and they weigh about 50 pounds. Children's life jackets should have a loop on the collar and a strap between the legs.

- ## 2 CHECK FOR DAMAGE

Check for tears on no buckle parts and no mold or rips in the fabric.

- ## 3 FASTEN UP

Fasten up all buckles, straps and straps. Adjust straps so that the jacket fits snugly.

- ## 4 CHECK FOR PROPER FIT

 - Life the shoulders of the life jacket.
 - Make sure it does not slip above the chin or ears.
 - It should feel snug, yet comfortable. A properly fitted life jacket keeps your head and shoulders above water. You will be able to swim with it, too.
- ## 5 WEAR IT!

A life jacket only works if it's worn. Take the time to be prepared. Make sure you have and wear the right life jacket before you go out in the water.



<http://www.watersafety.usace.army.mil>

Source: USACE National Water Safety Program
<http://corpslakes.usace.army.mil/employees/watersafety/art.html>

LIFE JACKET LOANER STATION

RULES & REGULATIONS:

- 1) Life jackets are available on a first-come-first-serve basis.
- 2) Parents/Guardians are responsible for making sure their children are in the right sized life jacket. If the size is incorrect, the life jacket will not work effectively.
- 3) Borrower assumes all responsibility and liability of life jacket use/non-use.
- 4) Borrower will not hold liable any party involved in the distribution of life jackets.
- 5) Borrower must inspect life jacket prior to use to make sure life jacket is in good working condition.
- 6) Return life jackets to this station before leaving the park!

ALWAYS SWIM
WITH A BUDDY,
NEVER ALONE!



THANK YOU FOR
YOUR COOPERATION!



Estación Para Prestar Chalecos Salvavidas

REGLAS Y REGULACIONES:

- 1) Las cantidades de chalecos salvavidas son limitadas.
- 2) Los padres ó guardianes tienen la responsabilidad de asegurar que sus niños tengan la talla correcta del chaleco salvavidas.
- 3) El prestatario asume toda la responsabilidad del chaleco salvavidas.
- 4) En caso de ocurrir un accidente, el prestatario no culpárá ningún representante del gobierno involucrado en la distribución de los chalecos salvavidas.
- 5) El prestatario debe examinar el chaleco salvavidas para asegurar que el mismo esté en buena condición.
- 6) ¡Devuelva los chalecos salvavidas a esta estación antes de salir del parque!

¡Gracias por su cooperación!

¡SIEMPRE NADE
CON UN AMIGO,
NUNCA SOLO!



US Army Corps
of Engineers®

Sample Graphic for Loaner Station

(high resolution versions available from National Water Safety Team)



DEPARTMENT OF THE ARMY
U.S. ARMY CORPS OF ENGINEERS
WASHINGTON, D.C. 20314-1000

JUL 23 2010

REPLY TO
ATTENTION OF

CECW-CO

MEMORANDUM FOR COMMANDERS, MAJOR SUBORDINATE COMMANDS AND DISTRICT COMMANDS, CHIEFS, OPERATIONS DIVISIONS AND CHIEFS, NATURAL RESOURCES MANAGEMENT, MAJOR SUBORDINATE COMMANDS

SUBJECT: Life Jacket Loaner Program Policy

1. References:

- a. Life Jacket Mandate Study Interim Report, 2 May 2008
- b. Title 31 USC, Principles of Federal Appropriations Law (GAO Redbook)
- c. CERM-F Memorandum, Subject: Public Safety Promotional Materials, 27 November 2002
- d. ER & EP 1130-2-550, Chapter 2 – Recreation Management, 15 November 1996

2. This memorandum provides policy to clarify the use of appropriated funds for purchasing supplies and materials to establish and maintain life jacket loaner programs on U.S. Army Corps of Engineers projects. The Corps Life Jacket Loaner Program was authorized to help reduce the number of public fatalities at Corps projects. Currently, over 90% of all drownings at Corps projects could have been prevented if a life jacket had been worn by the victim. Broader implementation of the Corps Life Jacket Loaner Program was one of the recommendations presented in the 2007 Life Jacket Mandate Study (LJMS) interim report prepared for MG Don Riley, then USACE Director of Civil Works. MG Riley endorsed that recommendation along with life jacket policy testing and the remaining report recommendations. The LJMS interim report can be viewed online at <http://corpslakes.usace.army.mil/employees/watersafety/ljms.cfm>.

3. The guidance for this policy is derived from Title 31 United States Code and the General Accounting Office, Principles of Federal Appropriations Law (GAO Red Book) as explained further in references 1.b. and 1.c. This guidance is further derived from the implication of the purpose statute, which directs that appropriated funds may only be used for the purpose for which they were appropriated. See 31 U.S.C. Sec. 1301(a). Not every expenditure must be expressly authorized to be permissible. However, if not expressly authorized, a proposed expenditure must be analyzed under the "necessary expense" test. This test provides that an agency expenditure, even if not specifically authorized by law, is still permissible if deemed reasonably necessary to carry out an authorized function or contributes significantly to the effective accomplishment of that function, and it is not otherwise prohibited by law.

CECW-CO

SUBJECT: Life Jacket Loaner Program Policy

4. Promoting public safety is an authorized agency purpose for managing the USACE Recreation Program as directed in reference 1.d., which contains a stated objective "To provide a quality outdoor recreation experience which includes an accessible, safe and healthful environment to a diverse population." Furthermore, this regulation directs public education stating that "Project personnel will promote, develop, and maintain public interest in recreation safety through the establishment of water safety councils or by participation in other local water safety educational opportunities."
5. Life jacket loaner programs have been established by USACE and other public safety agencies for backup provision of life jackets for visitors who inadvertently come to recreational lakes without one. Loaner stations have been successfully used as a tool to educate people about wearing the proper size and type of life jacket while recreating on our waters, further supporting our goal to reduce public recreation fatalities. Many of the existing loaner programs are made possible through donations and continued support of partnering organizations such as Safe Kids Coalition, local water safety councils, and BoatUS. Corps projects are encouraged to continue to seek partners to supplement the expenditures necessary to maintain these facilities.
6. Loss of life jackets from loaner stations has not typically been a problem; however, it is recommended that loaner life jackets are dispensed in a reasonably controlled manner and that losses be recorded and tracked. Excessive loss should immediately lead to actions to minimize theft or vandalism, including relocation or removal of loaner stations or initiation of manned check-out locations, such as at fee booths, visitor centers or similar staffed areas. Corps projects are encouraged to implement sign out programs to monitor the use and return of these life jackets, as well as schedule routine life jacket inspections to ensure that devices are maintained in safe and functional condition. This recommendation does not eliminate use of unmanned stations so long as proper public information regarding use and fitting of life jackets is posted, as well as clear indication that the devices are to be returned that same visitor day.
7. Additional information regarding life jacket loaner programs, signage and station designs can be found on the NRM Gateway, or by contacting the National Operations Center for Water Safety, ATTN: Lynda Nutt, lynda.g.nutt@usace.army.mil or Rachel Garren, rachel.j.garren@usace.army.mil.

FOR THE COMMANDER:



MICHAEL G. ENSCH
Chief, Operations
Directorate of Civil Works